



Installation Manual

Airlite Shop Fan

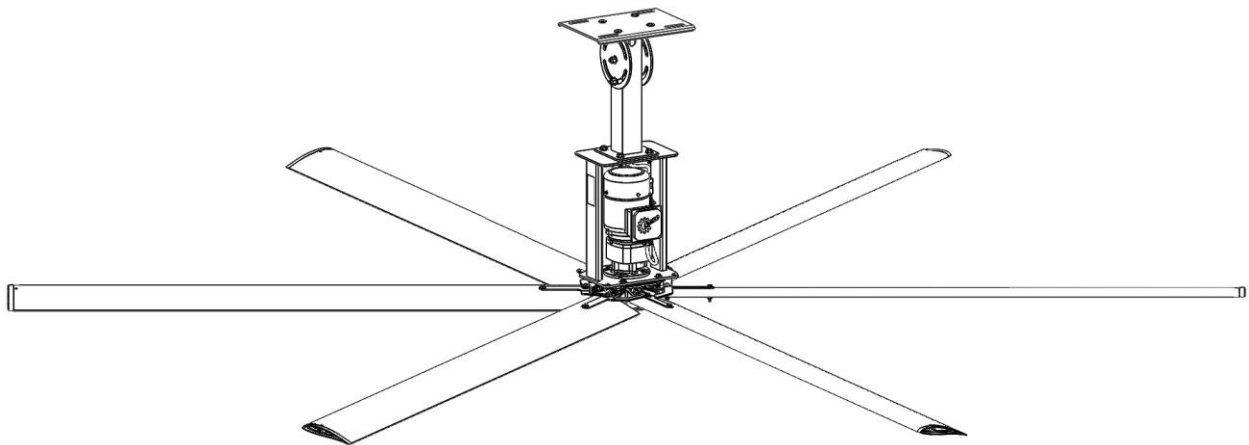

Table of Contents

Pre-Installation Checklist	Pre-Installation Checklist	2
Introduction	Caution & Safety	3
	Fan Clearance and Placement	6
Pre-Installation	I-Beam/Glulam Chart, Max Amp Draw	7
	Fan Dimensions & Components	8
	Rigid Mount & Components	9
	VFD Control Box & Components	11
	Tools Required	12
Installation Overview	I-Beam	13
	Glulam	14
Installing the Fan	Rigid Mount I-Beam Mounting	15
	Rigid Mount Glulam Mounting	18
	Rigid Mount Unistrut Mounting	21
	Safety Cable Installation	23
Installing Fan Blades	Blade & Safety Link Assembly	24
Wiring the Fan	Electrical & Safety Cable Installation	26
	Attach to VFD	27
	Fan Operation.	28
Information	Maintenance	29
	Troubleshooting	30
	Warranty.	31

Literature (Pg. 3)

- Order Verification.** I have verified the order information. All components are accounted for.
- Read.** I have read this Installation Manual and all other instructions before installing this fan.

Power (Pg. 3-4)

- Power Requirements.** I have verified the incoming power supply is sufficient for the fan.

Safety (Pg. 4-5)

- Safety Familiarity.** I am familiar with the safety components and features of the fan. I have verified the presence of a safety cable, and safety retainer links.

Airfoils (Pg. 5-7)

- Height from Floor.** I have verified the airfoils will be at least 10ft (3.05 m) above the floor.
- Application Clearance.** I have consulted the manual to determine that the airfoils will meet or exceed the clearance requirements regarding obstructions, or other fans.
- Airfoil Reach.** I have verified the airfoils will be mounted such that they are at least 3 feet away from any area where someone can extend outward and reach them.
- High Winds.** I have verified the fan will not be subjected to high winds from any outside influences, such as large garage door openings or HVAC systems.
- Diffuser Interference.** If diffusers are present, I will ensure that the fan is mounted at least 1.5X the diameter of the fan away from any source of airflow.
- Airfoil Compatibility.** I have verified the Airfoils and other fan components are those that shipped with the motor unit.
- Installing Multiple Fans.** I will not mix and match any hardware or blades.

Structure (Pg. 6-8)

- Application Suitability.** I have verified the application was approved by a structural engineer. I have checked the hanging weight and torque specs in the installation manual to ensure that the mounting structure can withstand the forces generated by the fan.
- Structural Suitability.** I have verified the building structure is suitable for this fan mounting. The fan will be mounted to an I-beam or Glulam or similar. I will not mount the fan to a single purlin, truss, or bar joist. I will consult a structural engineer for mounting not covered herein.
- Mount Suitability.** I have the appropriate mount for this application. I have verified in the installation manual that the mounting option provided is suitable for this application. I will consult a structural engineer for applications and mounting methods not covered herein.

Caution and Safety

This appliance can be used by children aged from 8 years and above and persons with reduced physical, sensory or mental capabilities or lack of experience and knowledge if they have been given supervision or instruction concerning use of the appliance in a safe way and understand the hazards involved.

Children shall not play with the appliance. Cleaning and user maintenance shall not be made by children without supervision.

⚠ ATTENTION: Safety. READ AND SAVE THE ENTIRE MANUAL BEFORE OPERATING THE FAN. Ensure that all safety procedures and instructions are followed during the installation, operation and servicing of the fan. Failure to apply these safety practices could result in death or serious injury. If you do not understand the instructions, please call our Technical department for guidance.

⚠ CAUTION: Non-Compliance. The fan installation should follow the recommendations outlined in this manual. MacroAir is not responsible for any injury or damage to persons or property because of 'not complying' with the recommendations outlined in the manual.

Electrical Guidelines

⚠ WARNING: Electrical Damage. Improper electrical installation can cause damage to the fan and interfere with other electronic equipment. In addition to standard electrical safety considerations, please observe the following:

- **MacroAir Cables.** The wiring from the control panel to the fan MUST be by MacroAir supplied shielded cable.
- **Electrical Interference.** Separate incoming power and motor control cables by a minimum of six (6) inches.
- **Individual Fan Wiring.** Run wiring for each fan separately.
- **Multiple Fans.** Do not attempt to control multiple fans from one (1) control panel.
- **ALWAYS GROUND PROPERLY.** Connect the supplied cable glands to each end of the motor cable and tighten them securely at both the fan motor and control panel ends. Connect the ground bar in the control panel to ground at the main breaker and test.
- **Read.** Please refer to the installation instructions for more information.

⚠ ATTENTION: Qualified Technicians. All fan controls should only be installed by qualified technicians familiar with the requirements of the National Electrical Code (NEC) and local codes. Refer to appropriate portions of this manual for other important requirements. Failure to follow these guidelines will void the manufacturer's warranty.

Electrical Guidelines cont.

⚠ ATTENTION: Factory Configured. All electrical controls are configured at the factory and are ready to use. No user adjustments are available. Follow the included wiring schematics and installation instructions when installing this device to ensure proper operation. Do not make any changes to any part of the motor control panel without first consulting MacroAir.

⚠ ATTENTION: Code Compliance. Installation is to be in accordance with the NEC, ANS/NFPA 70-1999 and local codes.

Hazard of Electrical Shock, Explosion or Arc Flash:

⚠ ATTENTION: Read. Read and understand this manual before installing or operating a fan unit. Installation, adjustment, repair, and maintenance must be performed by qualified personnel.

⚠ ATTENTION: Code Compliance. The user is responsible for compliance with all international and National Electrical Code requirements with respect to grounding of all equipment.

⚠ WARNING: Do Not Touch. Many of the parts of this unit operate at line voltage. DO NOT TOUCH.

⚠ WARNING: Covers. Install all covers before applying power or starting and stopping the unit.

Installation and Service

⚠ WARNING: Damage. Do not operate or install any fans or fan accessories that appear to be damaged.

⚠ WARNING: Death and Injury. Failure to follow this instruction can result in death, serious injury, or equipment damage.

⚠ WARNING: Disconnect Power. If the fan does not operate properly using the procedures in this manual BE CERTAIN TO REMOVE ALL POWER TO THE UNIT and contact our technical department for further assistance.

⚠ CAUTION: Moving Parts. Keep all body parts clear of moving parts at all times.

⚠ ATTENTION: Qualified Technicians. All electrical troubleshooting and repair must be done by a qualified technician and meet all applicable codes.

Key Safety Systems

⚠ ATTENTION: Safety. MacroAir fans are engineered with key safety features to prevent pieces of the fan from falling in the unlikely event of a catastrophic failure. Used together, these systems and devices provide comprehensive protection to people, equipment and property.

Key Safety Systems, cont.

⚠ WARNING: Safety Cable. Install safety cable on EVERY fan. The safety cable, if installed per MacroAir specifications, will prevent the fan from falling in the unlikely event that the mounting system should fail.

⚠ WARNING: Safety Cable. A MacroAir fan should never be run without a properly installed safety cable, which is supplied with every fan along with all required hardware. You must install a safety cable for the warranty to be in effect.

⚠ WARNING: Blade Safety Links. Install the complete set of extended blade safety links, which connect each blade to the adjacent blades and reinforce the area between the mounting holes. This is an important precautionary measure which will help prevent a blade from falling should one break off at the hub for any reason.

⚠ ATTENTION: Mark the Floor to Alert Personnel. When mounting a fan in an area where materials may be elevated into its path, MacroAir recommends marking or painting the floor with a large crosshatched circle to alert personnel of the overhead location of fans.

Mounting Guidelines

⚠ WARNING: Weight Considerations. We recommend that a building structure be capable of holding approximately twice the stated hanging weight of the fan. If there is some doubt of this, a professional contractor or architect should perform a thorough evaluation of the building prior to purchasing the fans. MacroAir provides guidelines for mounting fans; however, it is the sole responsibility of the building owner and installer to ensure the safety of the mounting system, that the building structure is sound, and that the installation complies with all federal, state, and local codes.

⚠ WARNING: Torque. The maximum torque (twisting force) that must be handled by the mounting system, including the building structure, occurs at fan startup. For this Airlite Shop fan, maximum potential starting torque is 743 Ft-Lbs. When standard electrical controls are installed, the fan will never begin to approach this maximum because the standard variable-speed control system uses the soft-start fail.

⚠ ATTENTION: Check Federal, State, and Local Codes. Check all relevant codes to make sure that all product certifications, product listings, and building regulations are met. Code compliance is the responsibility of the installer.

⚠ WARNING: Welding. DO NOT attach the fan or fan mounting components to the building structure by welding that component to the structure. DO NOT cement the fan to the structure.

Clearance Guidelines

⚠ ATTENTION: Sprinkler Systems and Fan Placement. In any installation where fire sprinklers are in place, do not interfere with their correct operation. Fans should be located no less than 3 feet below a sprinkler and placed central to each sprinkler quadrant. Our standard variable-speed control system can be connected to a fire suppression control system, which will emergency-stop the fans in case of fire.

⚠ ATTENTION: Sprinkler Systems and Code Compliance. Prior to installing fans, review all codes applicable to sprinkler systems and fans to ensure code compliance. Refer to the wiring diagrams packaged inside the control panel for proper installation. If further advice is needed, you may contact our support staff. However, it is your sole responsibility to see that the installation is completed to code and is correct.

General Information on Fan Placement and Spacing

⚠ ATTENTION: Strobe and Performance. If possible, avoid mounting fans directly below lights or skylights to avoid any strobe effect caused by moving blades.

⚠ WARNING: Mezzanine Placement. If the building has a mezzanine, fans should be mounted so a person cannot reach a fan in any way from the upper level/deck. Make certain that fans are positioned so that blade tips are at least 3 feet away from any area where a person may be able to extend outward to reach them.

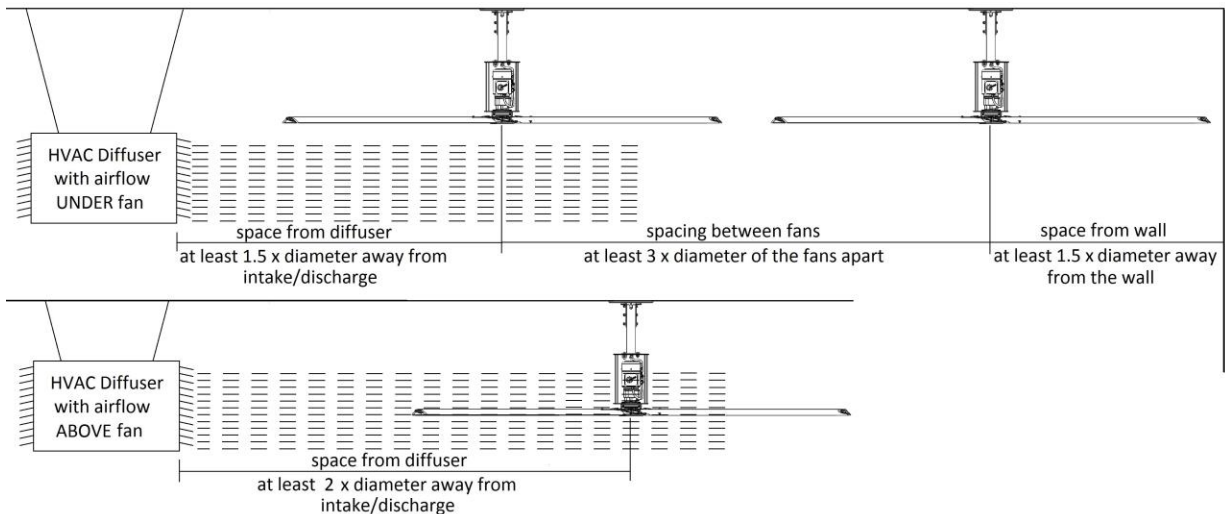

Figure 1: Fan Clearance and Placement

⚠ ATTENTION: The minimum distance of a fan to a wall or similar obstruction should be no less than 1.5 times the diameter of the fan. Reference Figure 1.

⚠ WARNING: FANS ARE NOT MEANT TO BE OPERATED IN WINDY CONDITIONS.

⚠ ATTENTION: Minimum Height. MacroAir requires that the fan blades must be a minimum of 10 feet (3.05 meters) above the floor. Contact MacroAir for assistance with fan placement.

I-Beam/Glulam Chart

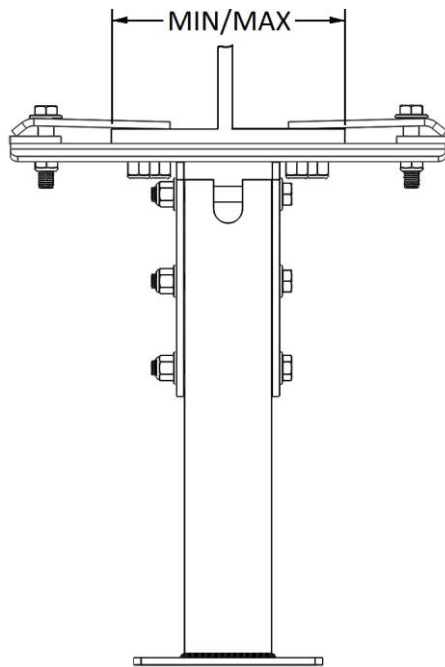

I-Beam Size Chart	
Range	
Min	Max
6.88" - 11.75"	

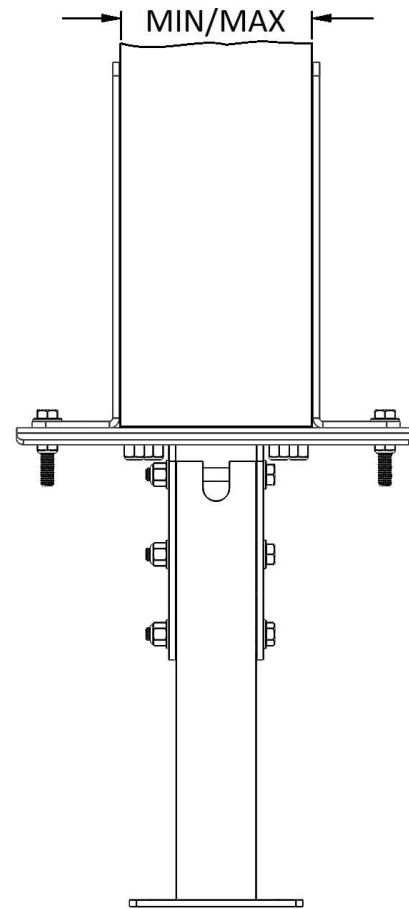

Glulam Size Chart	
Range	
Min	Max
4.63" - 10.00"	

The Min Range dimension is determined by using the inside slots of the Rigid Mount Bracket. The Max Range by using the outside slots of the Rigid Mount bracket.

Max Amp Draw

VOLTAGE AND PHASE	VFD MAX AMP DRAW
120VAC / 1 PHASE	16A

Fan Dimensions

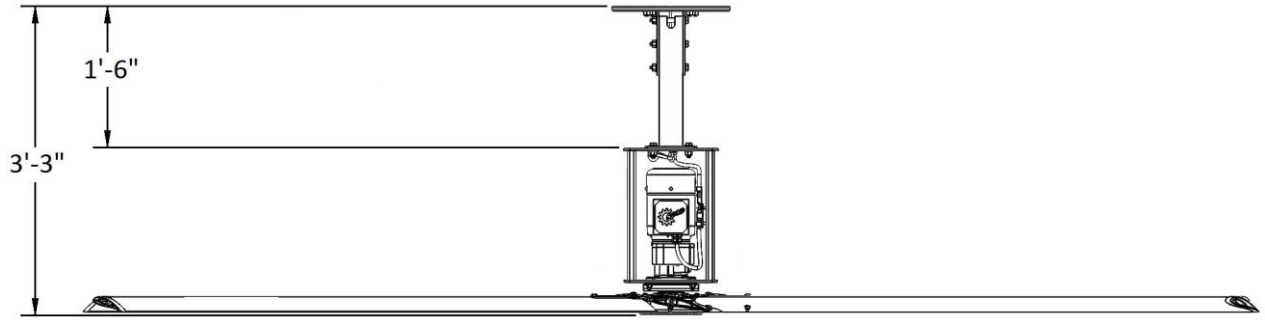

Fan Components

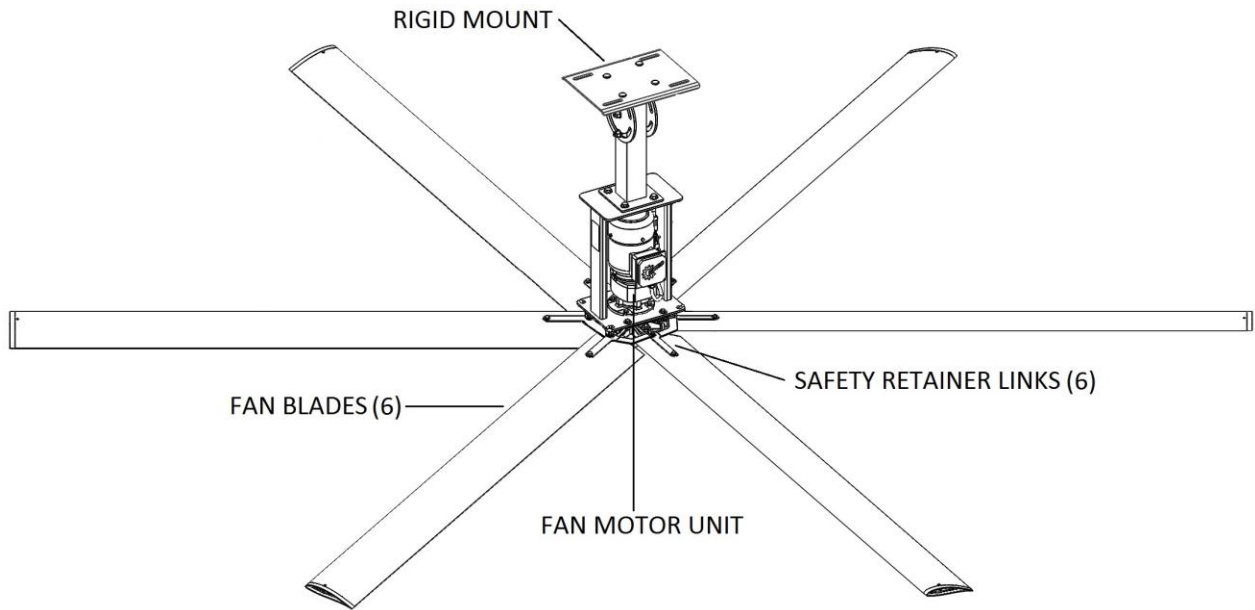

Rigid Mount & Components

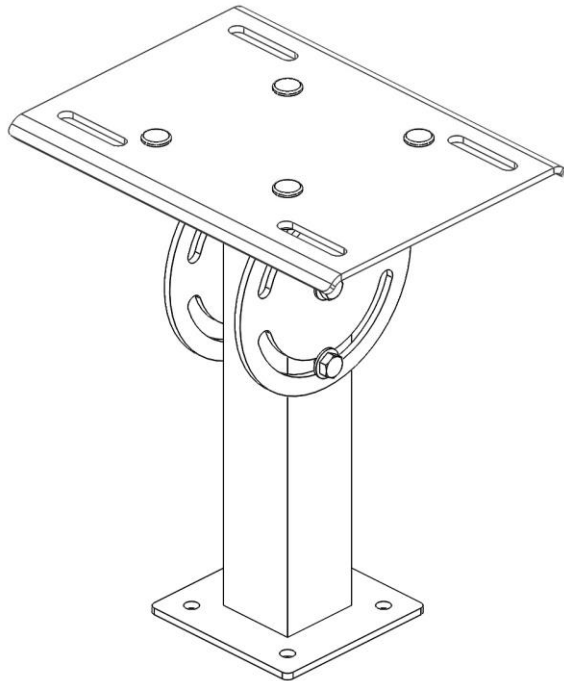

Rigid Mount

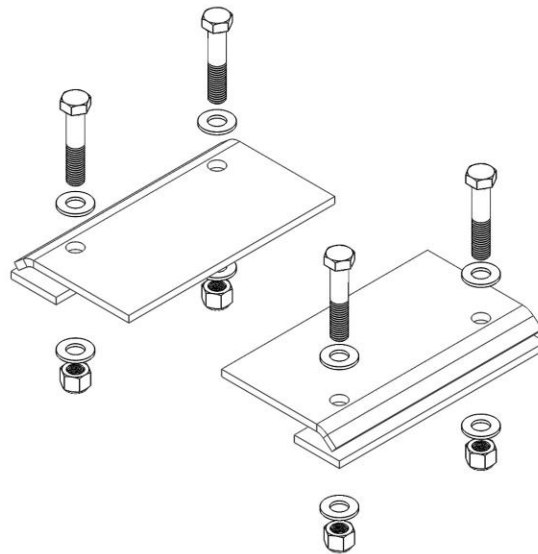

I-Beam Clamps & I-Beam Bolt Kit

- (2) I-Beam Clamps
- (2) I-Beam Shims
- (4) Hex Bolts 1/2"-32x2-1/2"
- (8) Washers, 1/2" Flat
- (4) Hex Nuts 1/2"-32, Nylon Lock

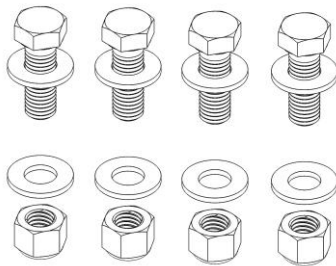

Rigid Mount Bolt Kit

- (4) Hex Bolts 1/2"-32x1-1/2"
- (8) Washers, 1/2" Flat
- (4) Hex Nuts 1/2"-32, Nylon Lock

Unistrut Mount Bolt Kit (optional)

Hardware Required but Not Provided:

- (4) 1/2"-13 x 1-1/2" Hex Bolts
- (4) 1/2" Flat Washer
- (4) 1/2" Unistrut Spring Nut

Rigid Mount & Components (cont.)

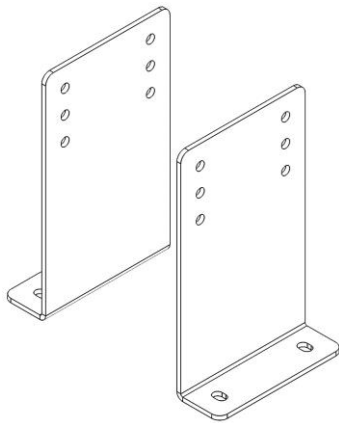

Glulam Brackets (optional)

Hardware Required but Not Provided:

- (4) 1/2"-13 Grade 5 Hex Bolts (at least 2-1/2" longer than Glulam)
- (8) 1/2" Flat Washers
- (4) 1/2" Nylon Lock Nuts

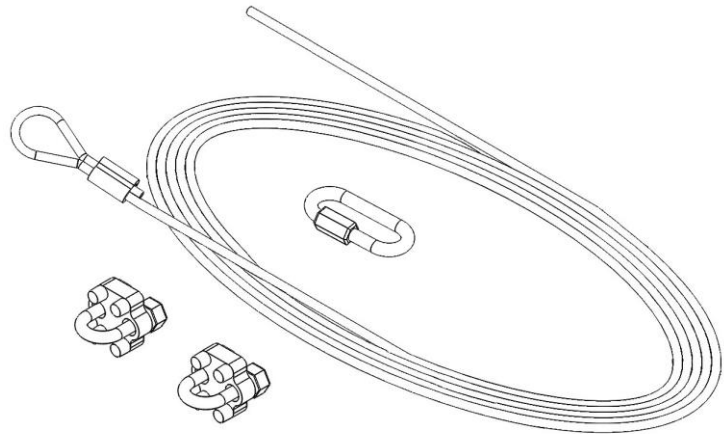

Safety Cable Kit

- (1) Wire Rope 3/16"
- (2) Wire Rope Clamps
- (1) Quick Link

VFD Control Box & Components

VFD Assembly

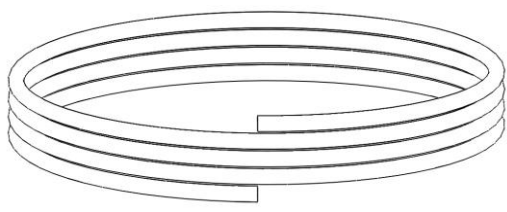
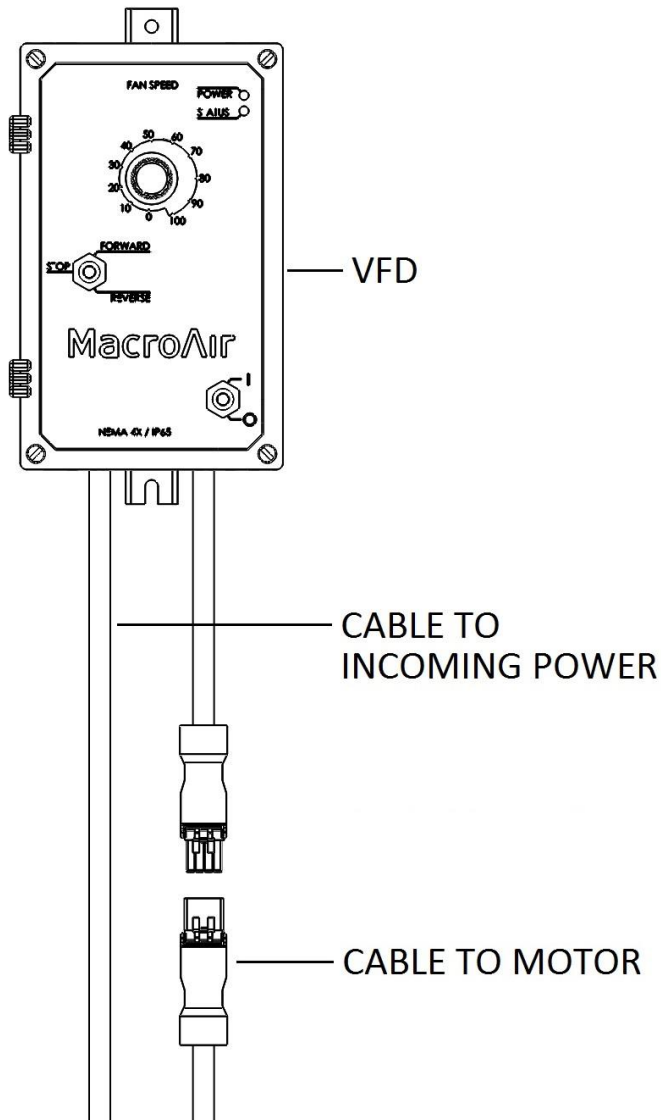

Incoming Power Cable (10FT)
(Part of VFD Assembly)

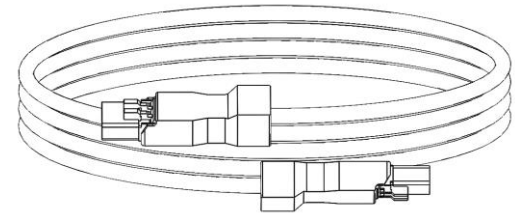

Motor Cable (50FT)

Tools Required

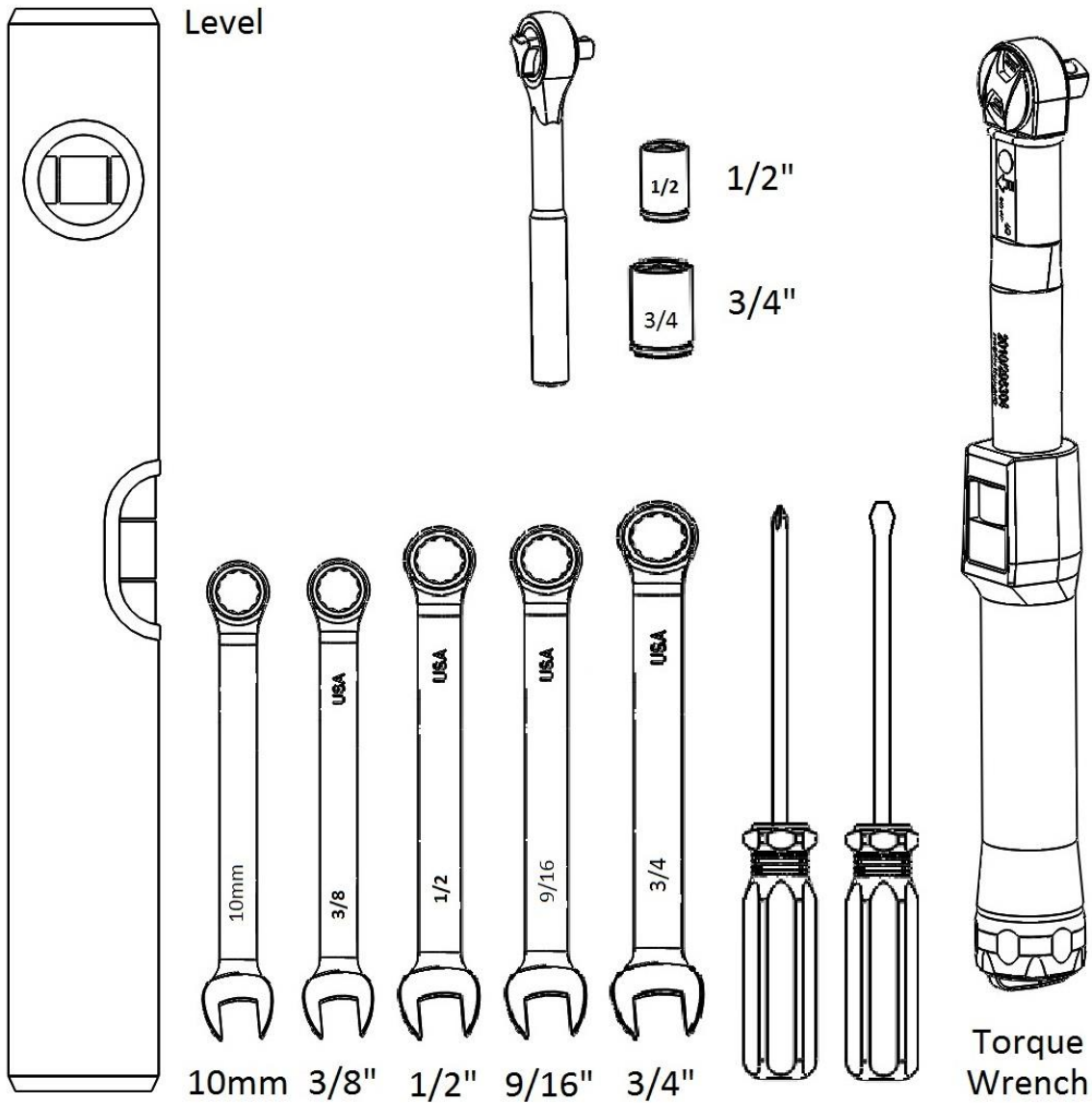

Note: A drill and drill bits will also be required when mounting brackets and control panel to Glulam.

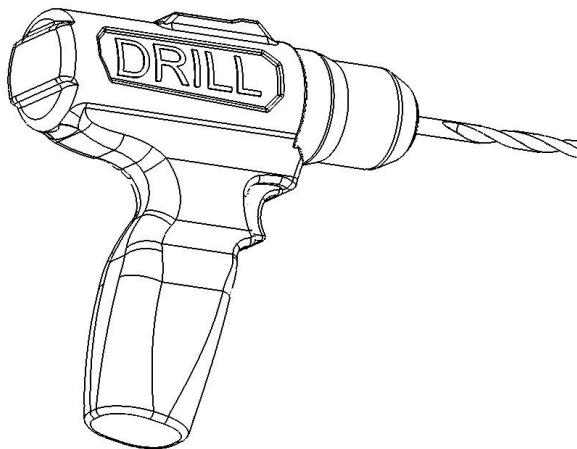

I-Beam

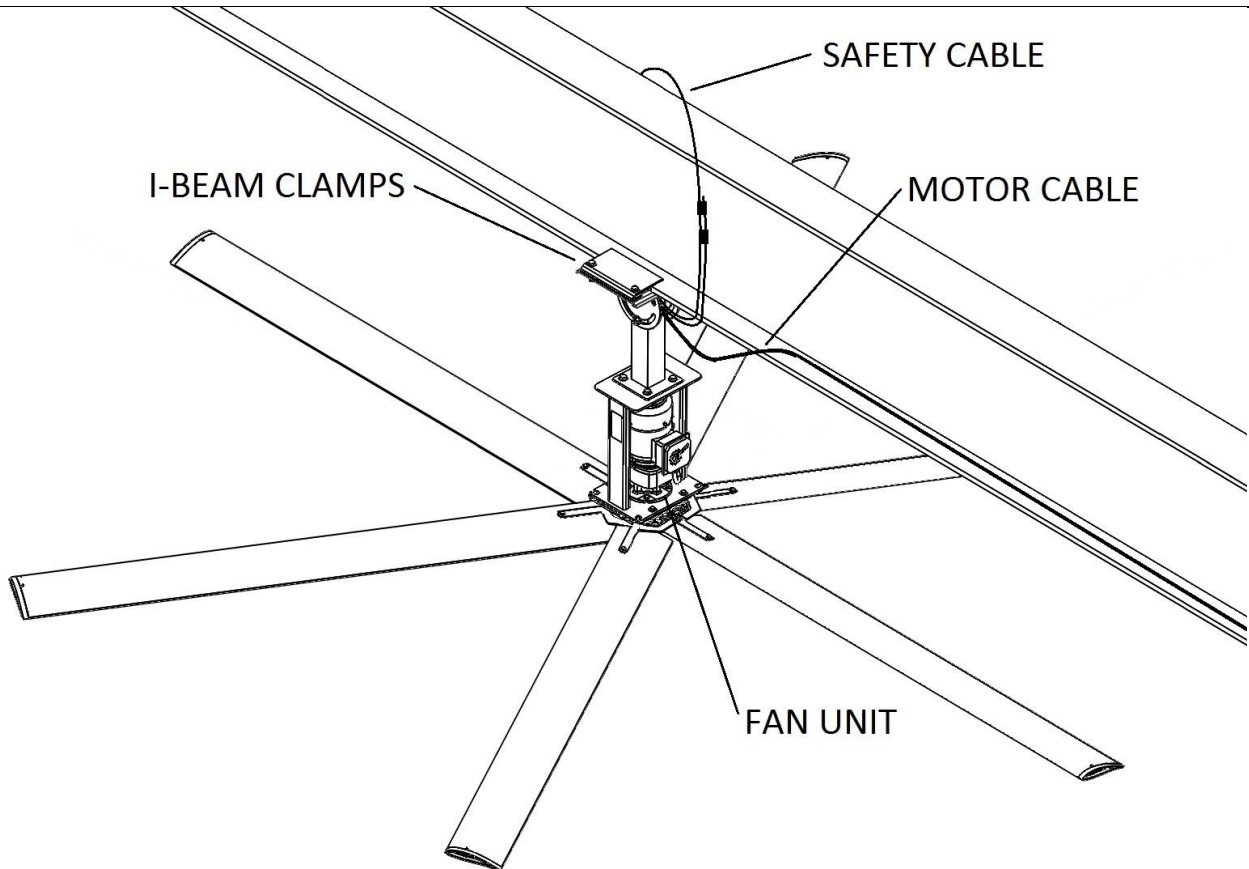

1. Mount Fan Unit to base of Rigid Mount using hardware pack, combination wrench, and socket wrench.
2. The Safety Cable needs to be fed from the quick link on the frame, through the Rigid Mount and then around the I-Beam.
3. 50 ft of Motor Cable is provided and used to connect the Fan Unit to the VFD. The cable is fed through the Rigid Mount to the Fan Unit Connection on the frame.

Glulam

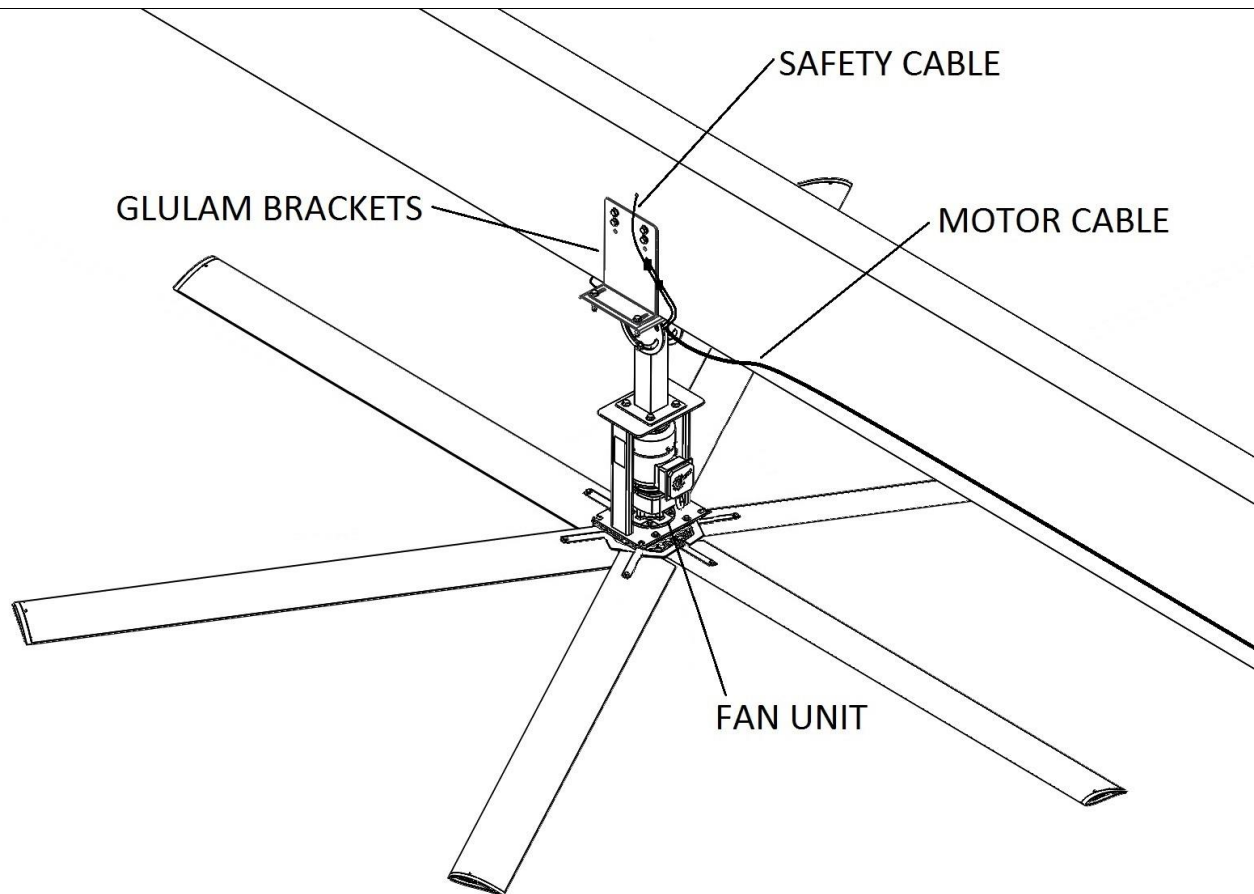

1. The Safety Cable needs to be fed through a hole in the Glulam, preferably above the center line of the Glulam.
2. 50 ft of Motor Cable is provided and used to connect the Fan Unit to the VFD. The cable is fed through the Rigid Mount to the Fan Unit Connection on the frame.
3. The Glulam brackets need to be through-bolted to the Glulam as high as possible.
4. Attach fan frame to the bottom of the Rigid Mount with the provided hardware, combination wrench, and socket wrench.

Rigid Mount I-Beam Mounting

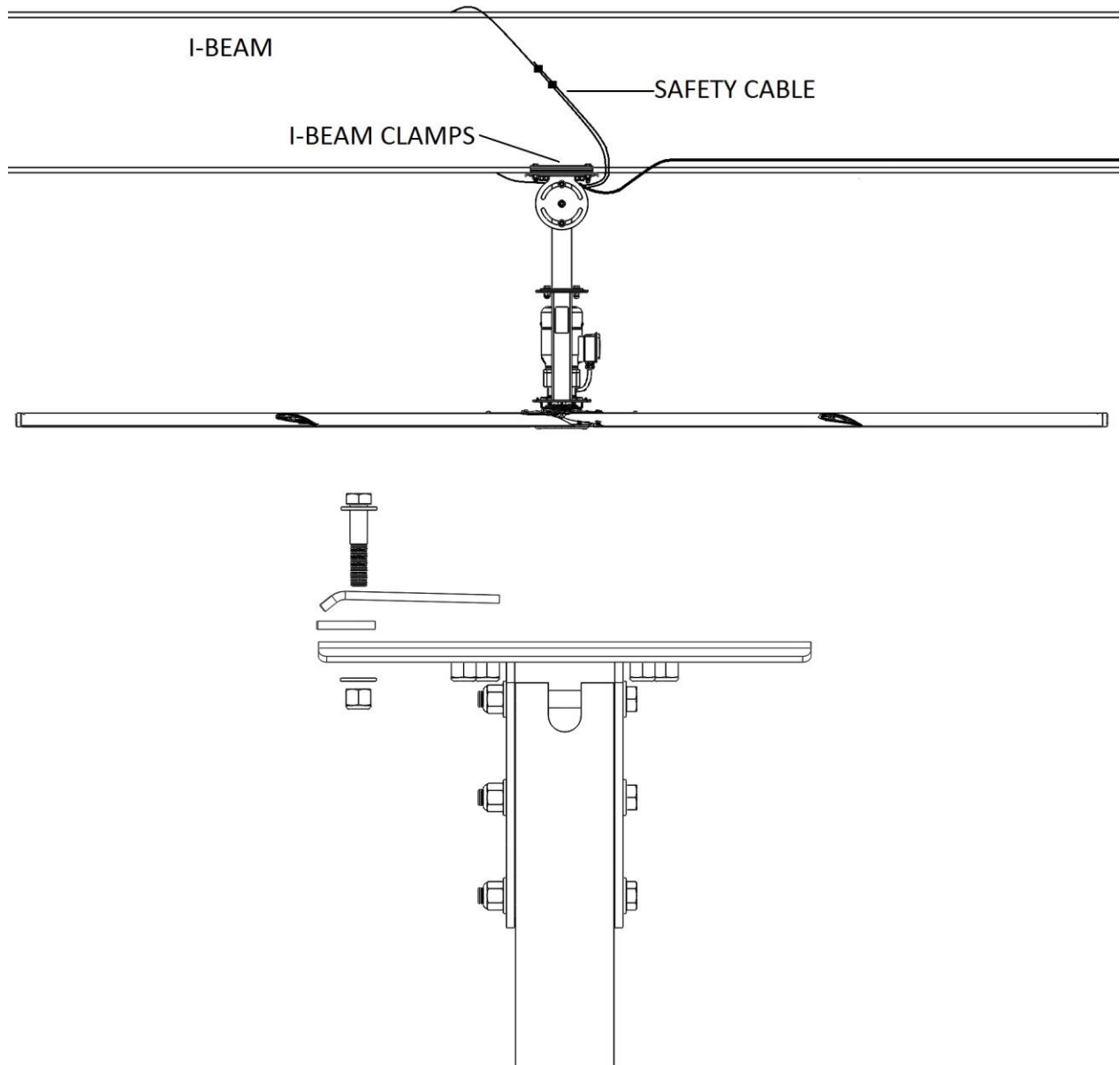

1. Assemble one side of I-Beam Mount with (1) Clamp, (1) Shim and Hardware.
2. Hand tighten Nuts to secure Clamp and Shim in place.

I-Beam Clamps & I-Beam Bolt Kit

- (2) I-Beam Clamps
- (2) I-Beam Shims
- (4) Hex Bolts 1/2"-32x2-1/2"
- (8) Washers, 1/2" Flat
- (4) Hex Nuts 1/2"-32, Nylon Lock

Rigid Mount I-Beam Mounting (cont.)

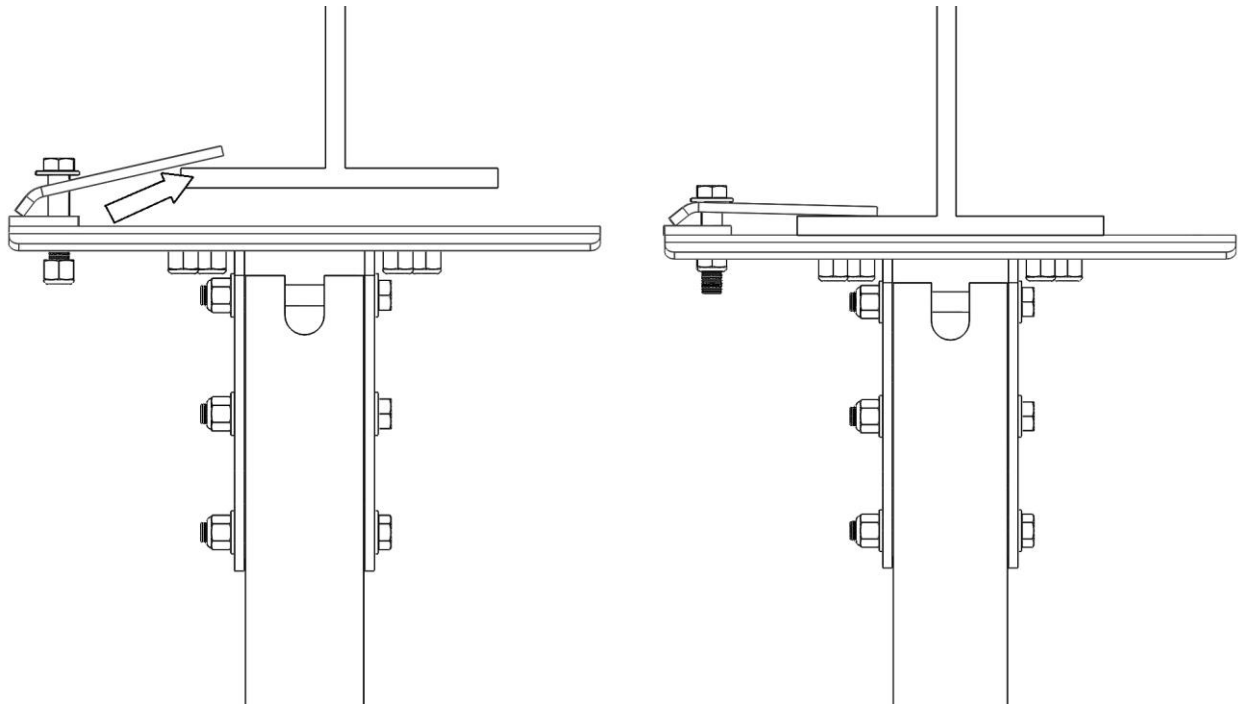

3. Position the Rigid Mount under the I-Beam so that one side of the beam is between the clamp and Rigid Mount.

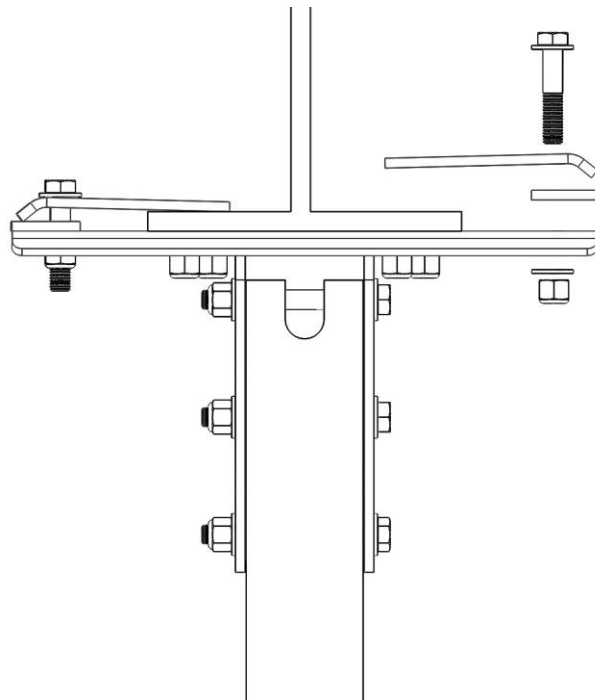

4. Assemble other side of I-Beam Mount with (1) Clamp, (1) Shim and Hardware.
5. Hand tighten nuts to secure Clamp and Shim in place.

Rigid Mount I-Beam Mounting (cont.)

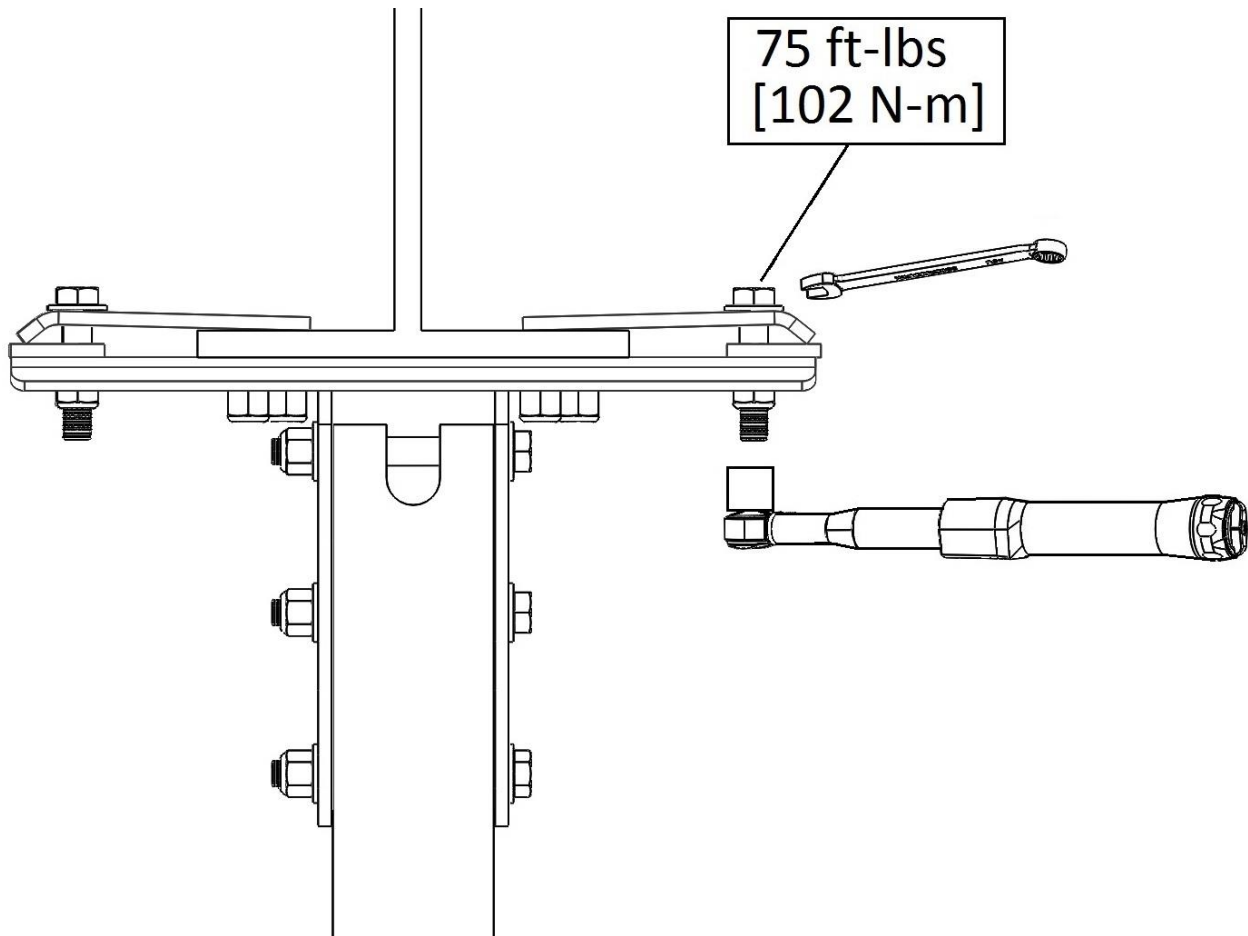

6. Center the Rigid Mount on the I-Beam.
7. Using a 3/4" combination wrench and a 3/4" socket and torque wrench tighten all hardware to 75 ft-lbs. [102 N-m].

Rigid Mount Glulam Mounting

This method is recommended for Glulams or wood beams 5-1/8" or wider. For narrower beams, span across two or more beams using the Unistrut mounting method. (Refer to page 23)

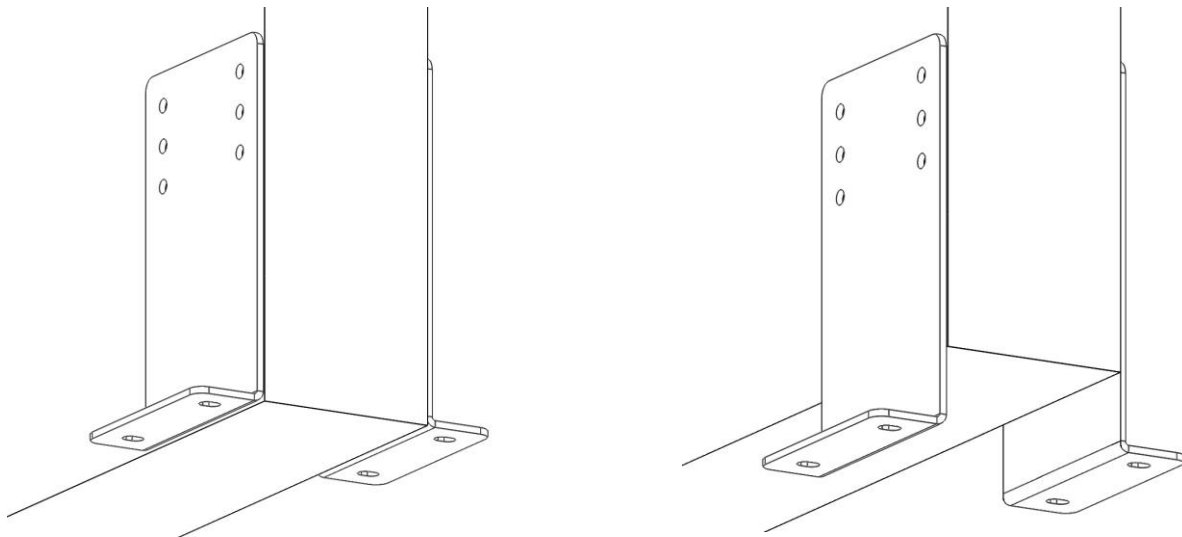
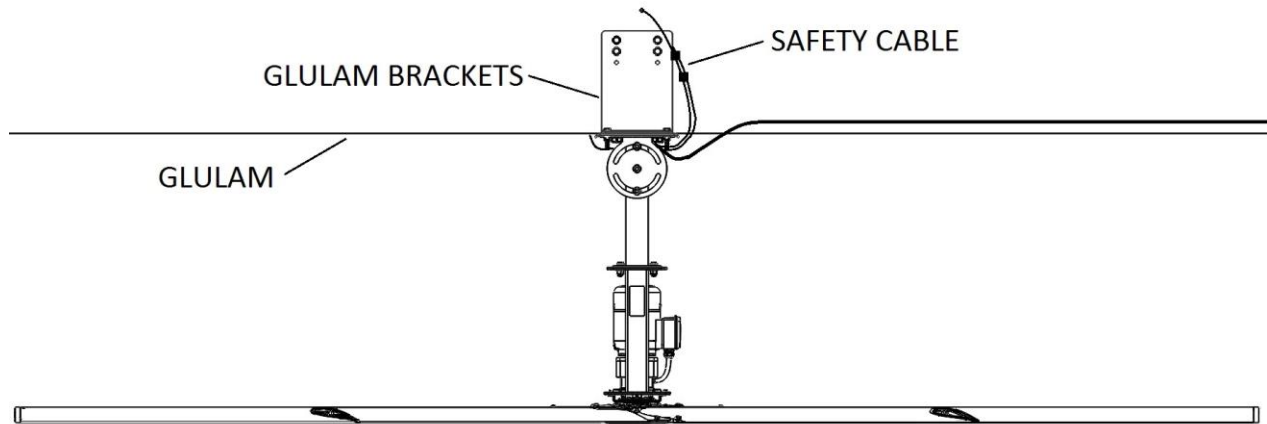

1. The Brackets can be located below the glulam if necessary but is not recommended. Locate brackets even with bottom of glulam.

Rigid Mount Glulam Mounting (cont.)

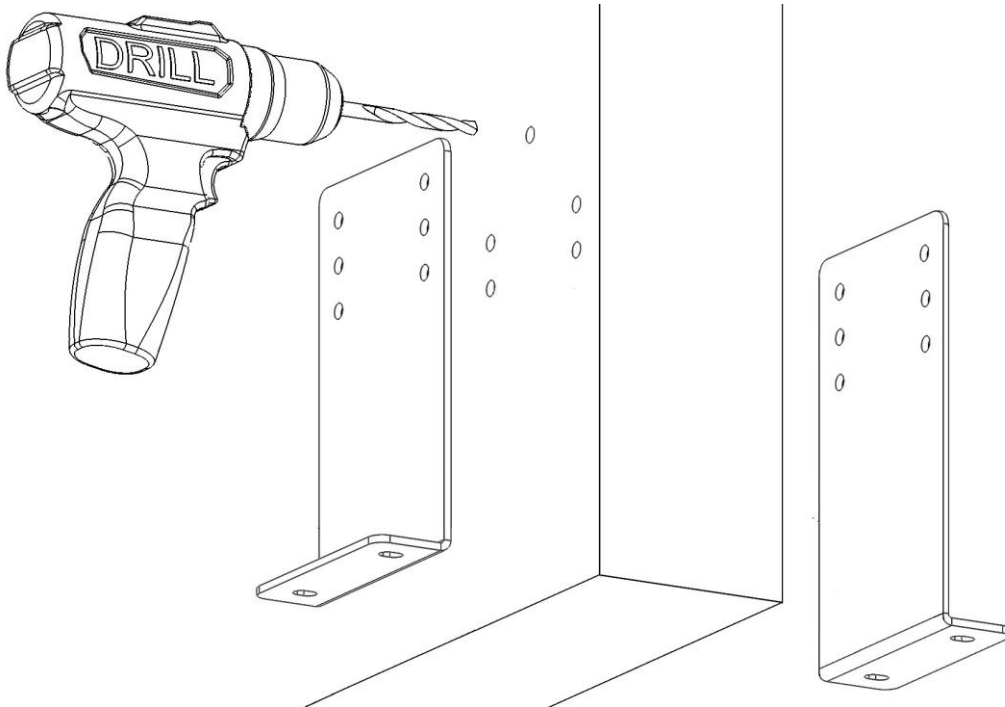

2. Drill maximum 5/8" diameter clearance holes through the glulam for (4) 1/2"-32 mounting bolts and (1) hole for the 3/16" diameter safety cable. The highest bolt hole should not be below the beam's center line unless the glulam is too tall. The hole for the safety cable should be centered above the brackets (preferably above the center line of the glulam).

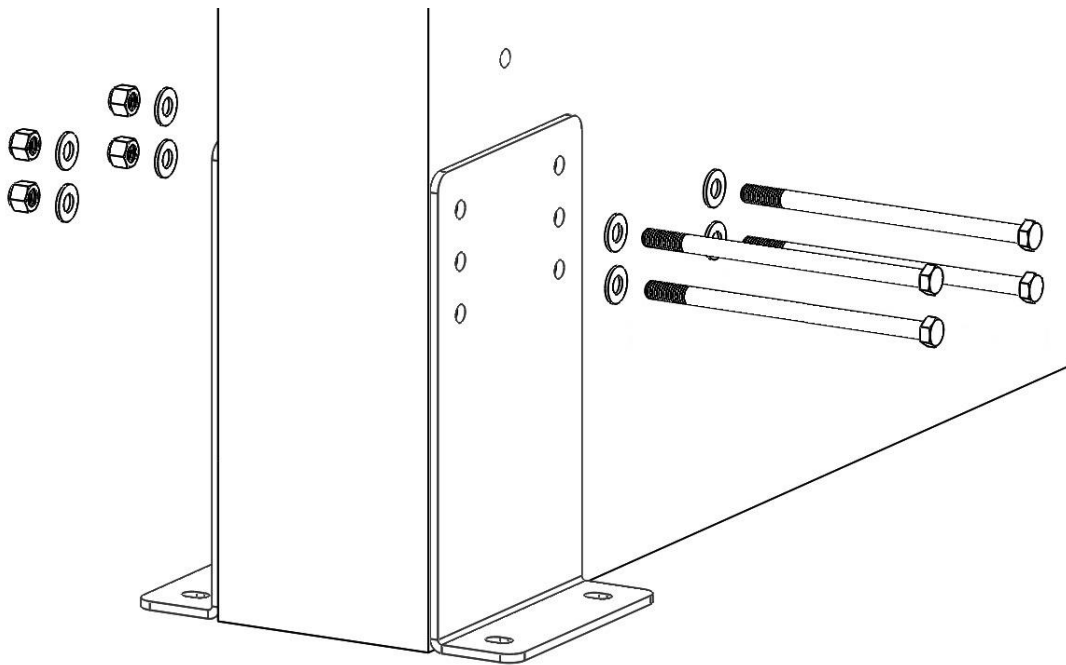

3. Secure the Glulam brackets to the Glulam via (4) 1/2"-13 grade 5 bolts (long enough to go through the entire beam with nylon lock nuts). Stack the Bolt, washer, and washer, nut as shown above.

Rigid Mount Glulam Mounting (cont.)

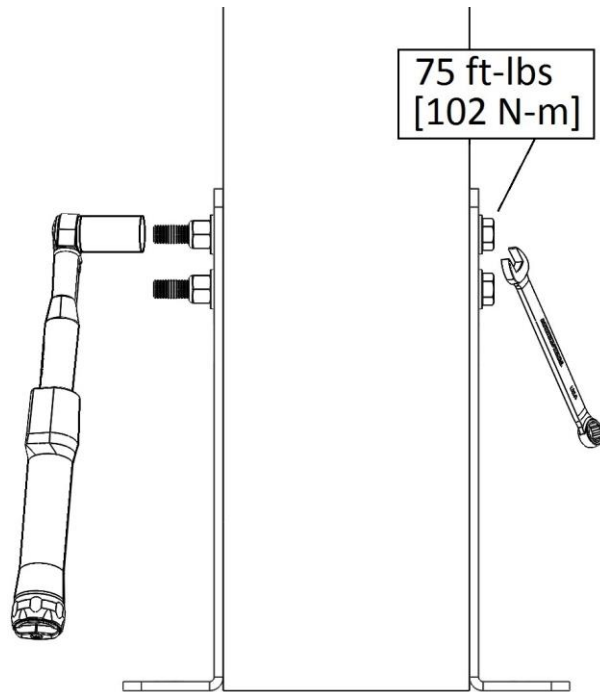

4. Using a 3/4" combination wrench and a 3/4" socket and torque wrench tighten all hardware to 75 ft-lbs.[102 N-m].
5. Mount the Rigid Mount to the glulam brackets using the supplied Bolt Kit which contains (4) 1/2"-13 x 1.50" Hex Bolts, (8) 1/2" Washers and (4) 1/2"-13 Nylon Lock Nuts. Using a 3/4" combination wrench and a 3/4" socket and torque wrench tighten all hardware to 75 ft-lbs. [102 N-m].

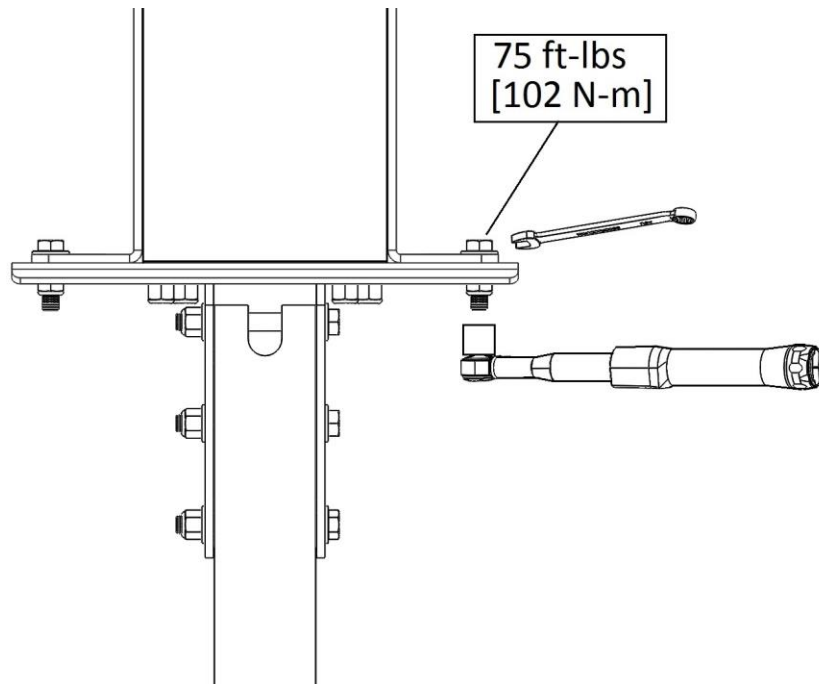

Rigid Mount Unistrut Mounting

This method is used to span components of a building structure. Attachment points to the building structure can vary greatly, so we recommend contacting Unistrut, so they can recommend the best method for attaching the Unistrut (www.unistrut.us).

1. Two (2) pieces of 1-5/8" x 1-5/8" 12-gauge Unistrut need to span the trusses. Distance apart to be centered over the widest hole pattern in the Rigid Mount being used (see step 2). Maximum allowable distance between trusses is 8 ft. If the spanning distance is greater than 8 feet, please consult a Structural Engineer. Please refer to page 5 for the maximum torque and weight values.

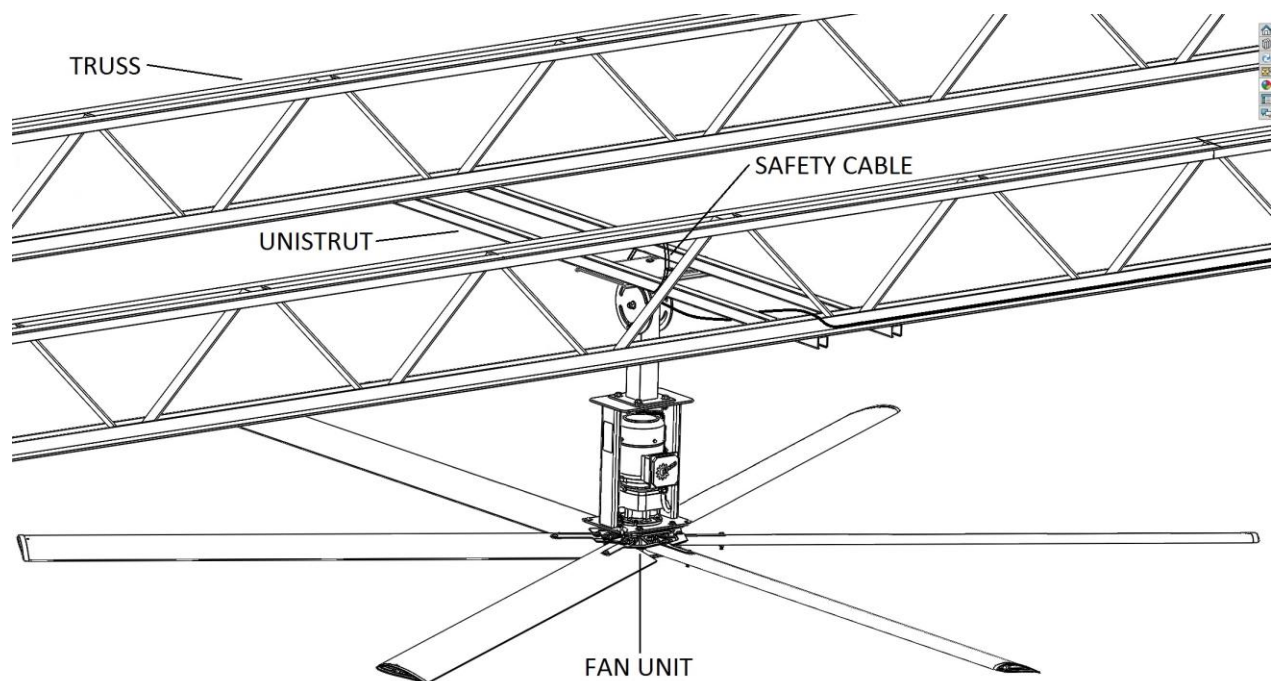

Hardware Required but Not Provided:

- (4) 1/2"-13 x 1-1/2" Hex Bolts
- (4) 1/2" Flat Washer
- (4) 1/2" Unistrut Spring Nut
- (1) Loctite 243

Rigid Mount Unistrut Mounting (cont.)

- Attach the Rigid Mount in the most desired position between the trusses using hardware indicated (not provided). Apply Loctite 243 to the 1/2"-13 bolts prior to mounting. Unistrut clamps are not permitted in this mounting method.

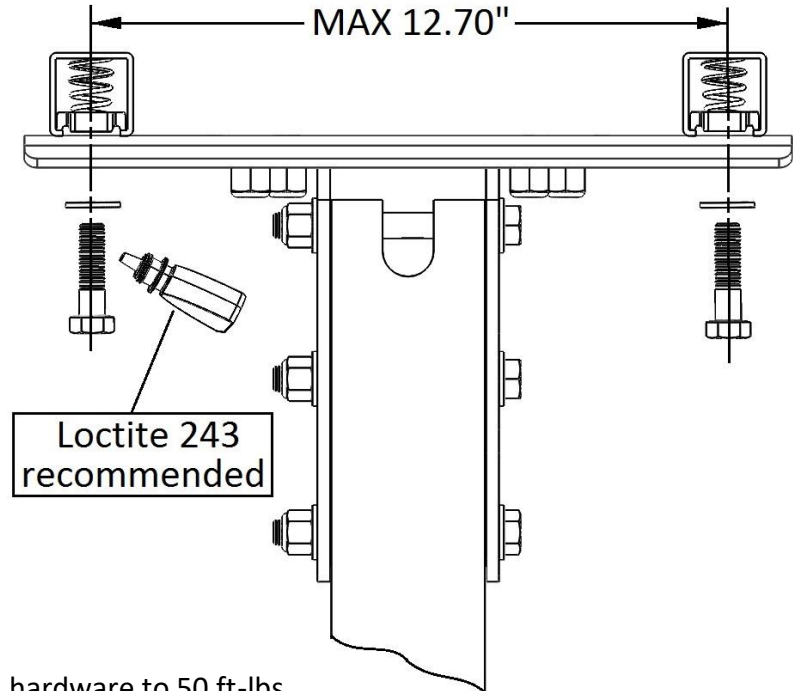

- Using a Torque wrench, tighten hardware to 50 ft-lbs.

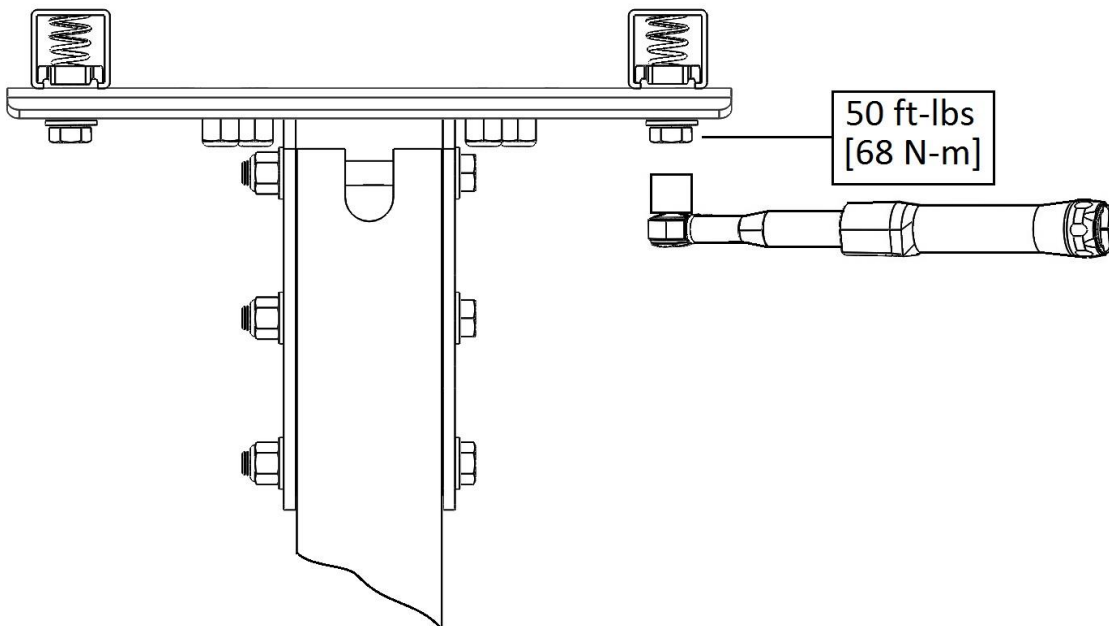

NOTE: Mounting to C- and Z-purlins requires Unistrut span mounting. Mounting to trusses under three (3) inches in width requires two or more trusses to be linked with Unistrut. We recommend contacting Unistrut, so they can recommend the best method for attaching the Unistrut (www.unistrut.us).

Safety Cable Installation

I-Beam

1. Attach safety cable to fan frame with quick link, feed up through Rigid Mount and around I-beam .
2. Secure two (2) safety cable clamps around the wire. Pull the cable taut and tighten both nuts using 3/8" combination wrench.

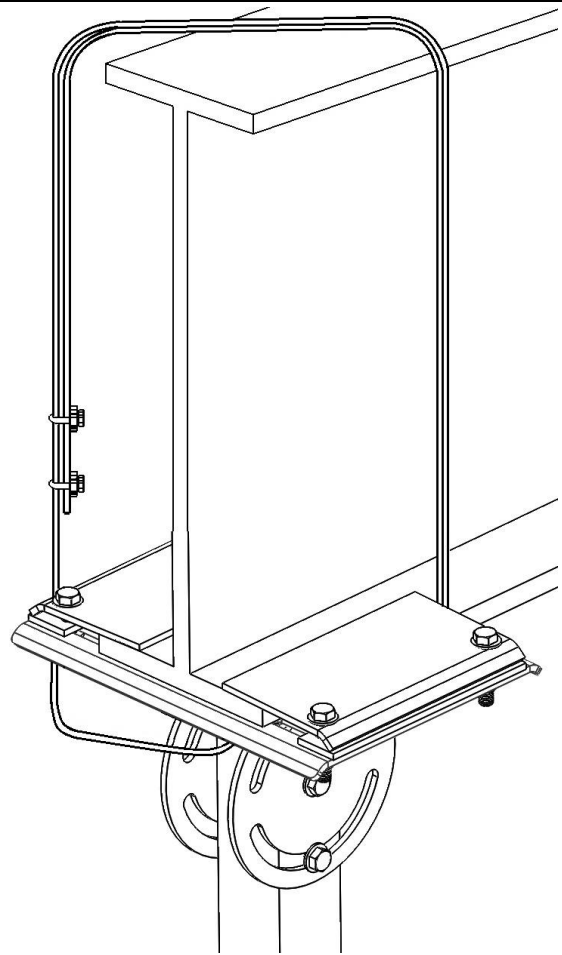
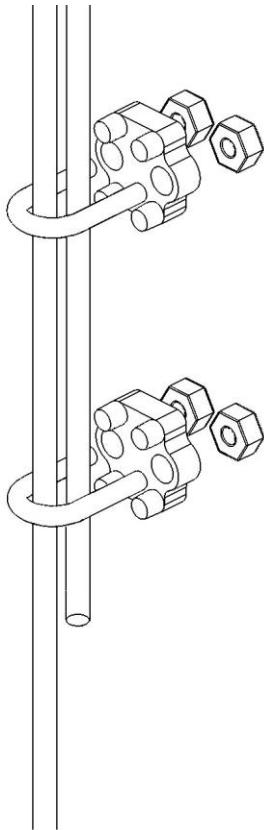

Glulam

1. Attach safety cable to fan frame with quick link, feed up through Rigid Mount and through hole drilled in Glulam above brackets.
2. Secure two (2) safety cable clamps around the wire. Pull the cable taut and tighten both nuts using 3/8" combination wrench.

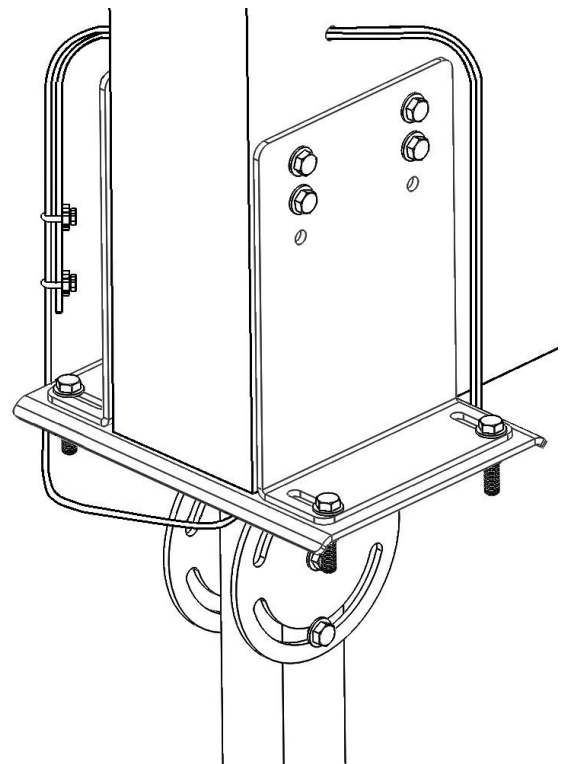

Blade & Safety Link Assembly

1. Apply the provided lubricant in 4 spots on the top and 4 spots on the bottom of each strut as indicated. Each line of lubricant should be in a groove of the strut, approximately 1"-1.5" long and spaced as indicated.

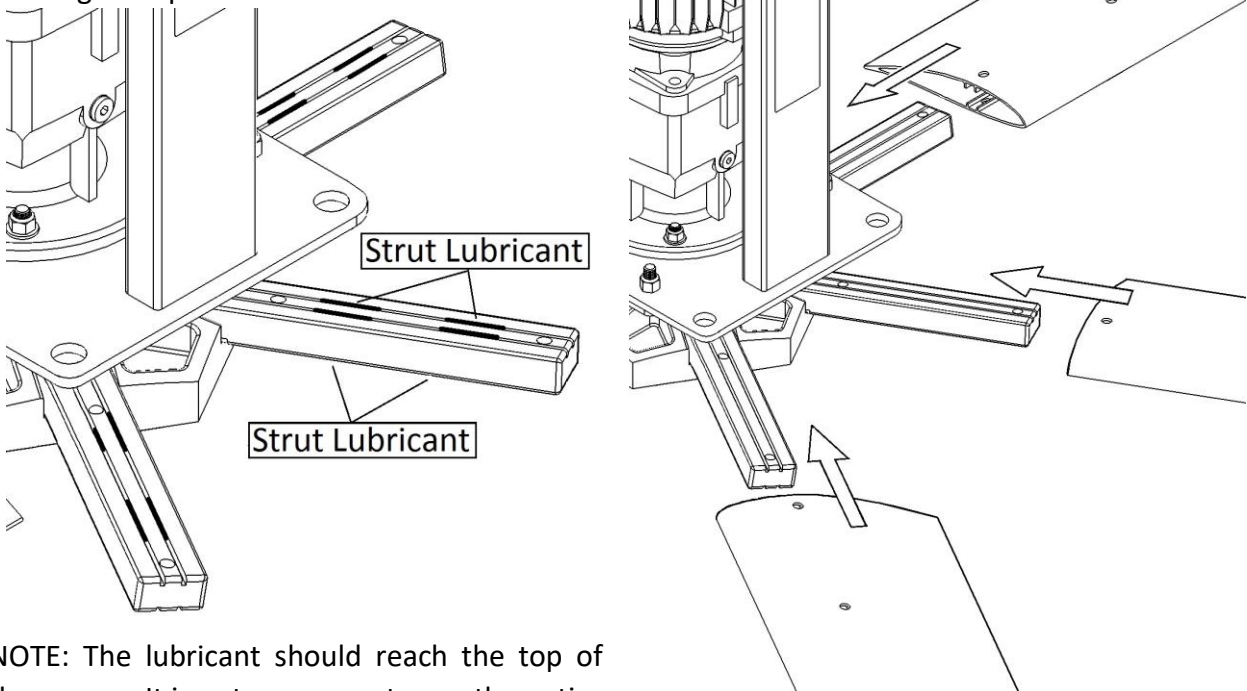

NOTE: The lubricant should reach the top of the groove. It is not necessary to use the entire tube.

2. Slide the blades onto the blade struts and align the mounting holes in the blade with the mounting holes in the blade struts.

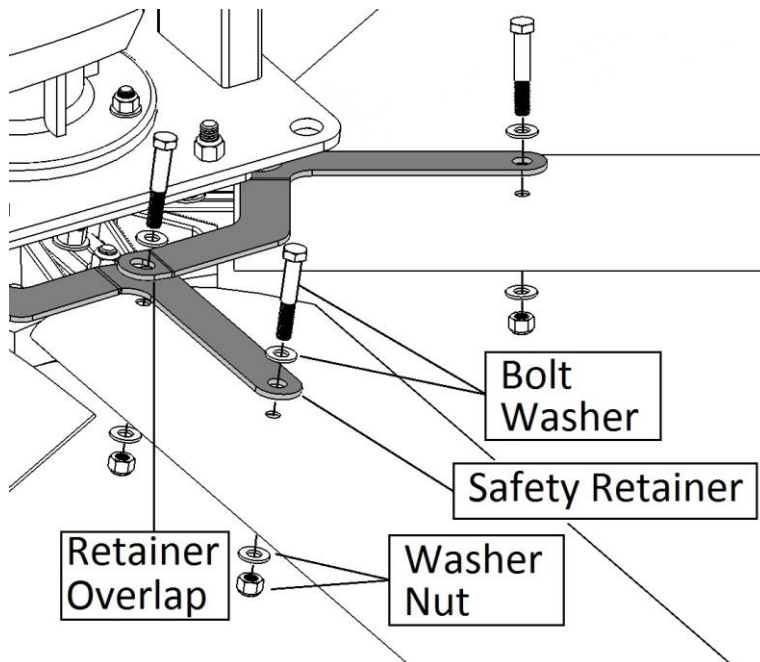

3. Once all the blades are in place, install the safety retainer links and blade bolts, washers, and nuts in a clockwise or counter-clockwise manner. Overlap each safety retainer link with the previous safety retainer link.

Blade & Safety Link Assembly (cont.)

4. Using a 3/4" combination wrench and a 3/4" socket and torque wrench tighten all blade hardware to 23 ft-lbs.

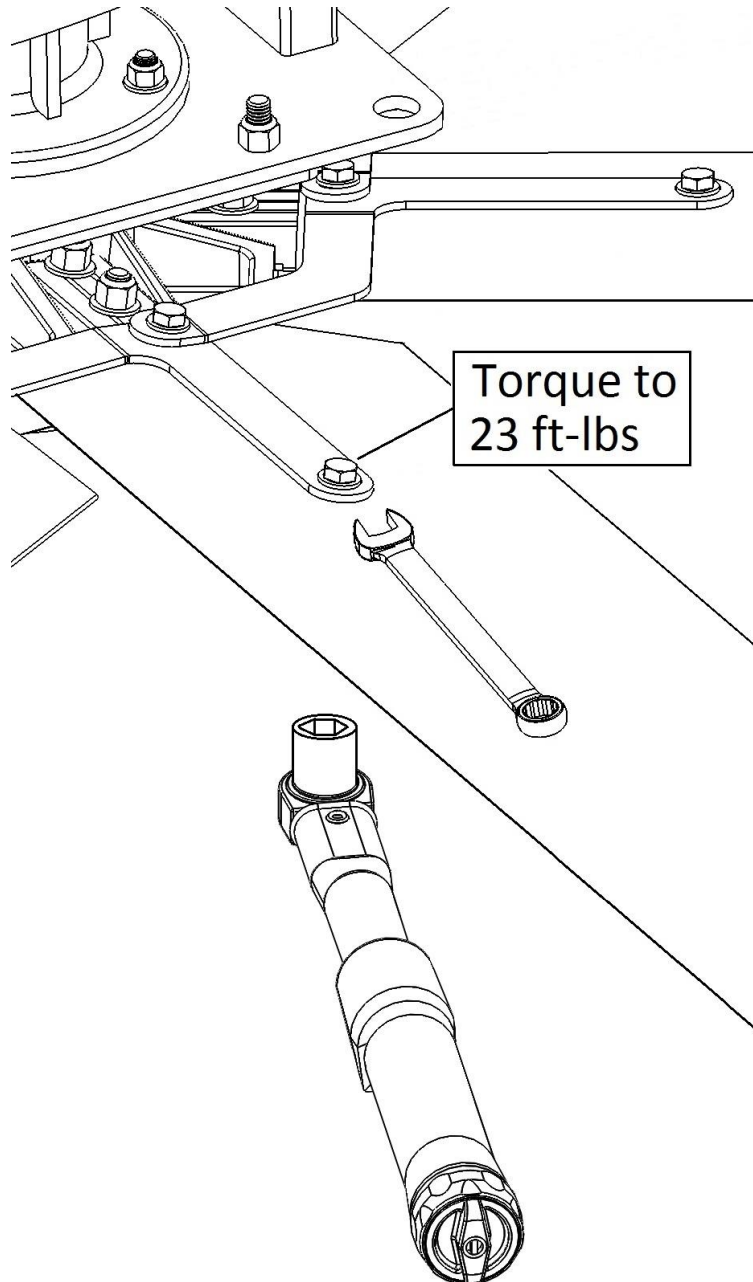

Electrical & Safety Cable Installation

⚠ WARNING: MOTOR CABLES AND INCOMING POWER MUST NEVER BE RUN IN THE SAME CONDUIT. FAILURE TO INSTALL PER MACROAIR INSTRUCTIONS, INCLUDING WIRING, MAY BE HAZARDOUS, CAUSE PREMATURE FAILURE, AND VOID THE MANUFACTURE'S WARRANTY.

⚠ ATTENTION: Regulatory Notice, EMI (Electromagnetic Interference)

Electromagnetic Interference (EMI) is any signal or emission, radiated in free space or conducted along power or signal leads, that endangers the functioning of radio navigation or other safety services or seriously degrades, obstructs, or repeatedly interrupts a licensed radio communications service. Radio communications services include but are limited to AM/FM commercial broadcast, television, cellular services, radar, air-traffic control, pagers, and personal communications services (PCS). These licensed services, along with unintentional radiators such as digital devices, variable frequency drives (VFDs), and other equipment such as fans with VFDs, contribute to the electromagnetic environment.

Electromagnetic compatibility is the ability of items of electronic equipment to function properly together in the electronic environment. MacroAir Fans variable frequency drives, VFDs, are designed to be in compliance with regulatory agency limits for EMI. However, there is no guarantee that interference will not occur in a particular installation. If MacroAir's products (fans) do cause interference with radio communications services, which can be determined by turning the fans off and on, please notify MacroAir technical support.

MacroAir Technologies' products are designed, tested, and classified for their intended electromagnetic environment. These electromagnetic environment classifications generally refer to the following harmonized definitions:

Class A is typically for business or industrial environment.

Class B (MacroAir products are **NOT** designed for typical residential environments covered under this classification).

CODE COMPLIANCE IS THE RESPONSIBILITY OF THE INSTALLER, AND ULTIMATELY, THE END USER. All wiring should conform to the National Electric Code (NEC) 2005, ANSI/NFPA 70-1999, and all local codes. This fan control should only be installed by qualified technicians familiar with the requirements of the NEC and local codes.

Note: MacroAir Technologies has a policy of continuous product improvement and reserves the right to change design and specifications without notice.

If you have any questions, please contact MacroAir technical support.

Attach to VFD

1. Feed one end of the 50' cable through the Rigid Mount and the top of the frame and plug it into the receptacle on the frame.

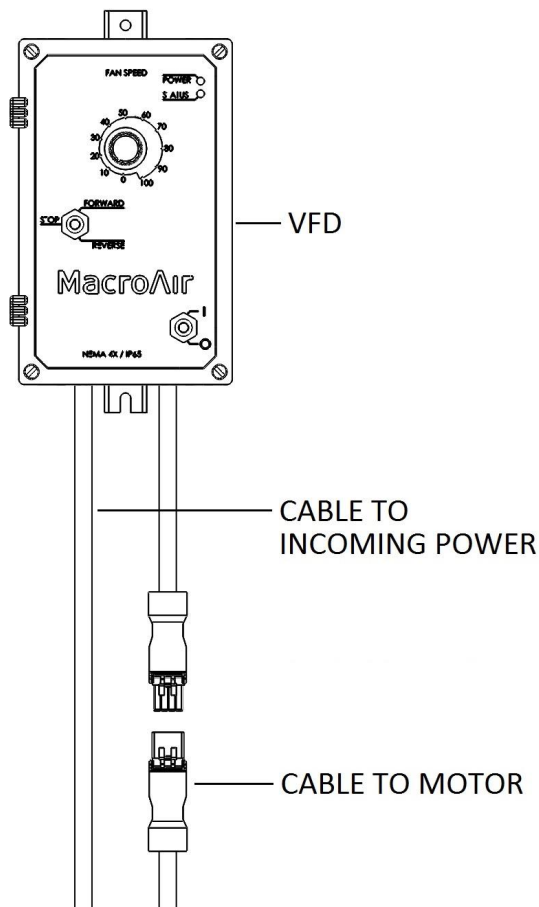
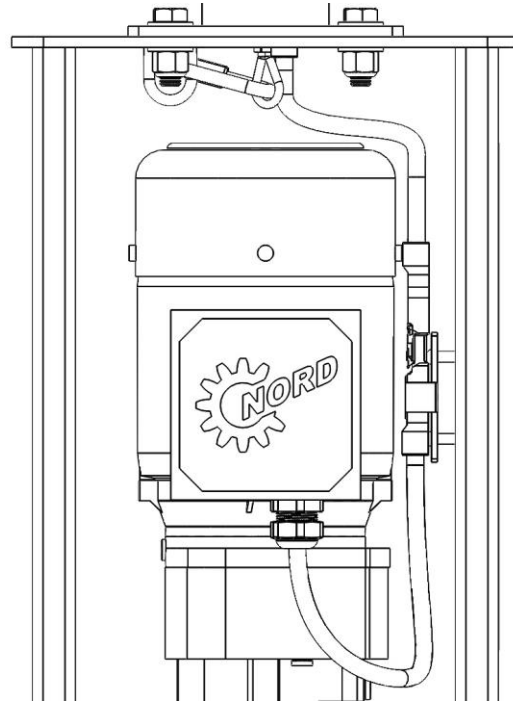

2. Attach the other end of the 50' cable to the receptacle on the VFD whip. Plug VFD into incoming power.

Fan Operation

1. Step 1: Turn on the fan.
2. Step 2: Select forward direction for cooling or reverse for destratification (heating).
3. Step 3: Adjust the speed dial to control how fast the fan rotates.

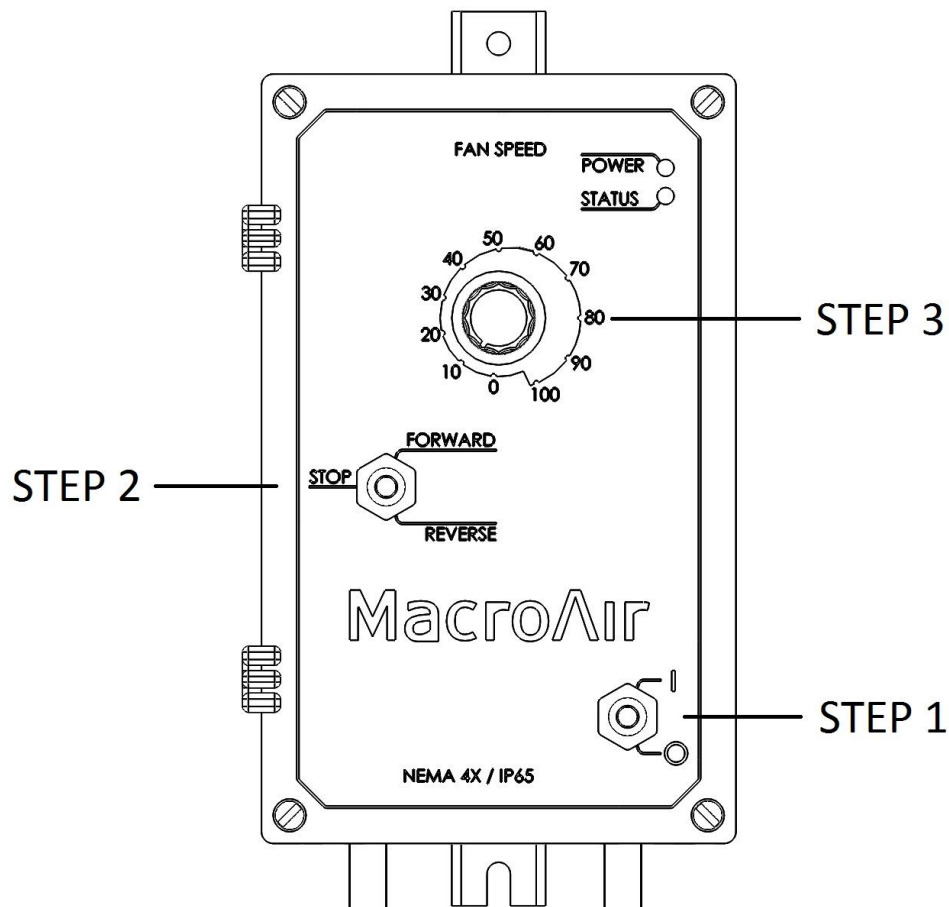

Maintenance

Airfoil Cleaning: Depending on the type of commercial application the MacroAir fan is in, there can be quite a bit of dust or other particulates that cling to the fan's airfoils. While this may not affect fan performance, we recommend fan owners keep airfoils clean by having a maintenance person or skilled trade professional – who has experience using a lift – wipe the fan airfoils with a rag or sponge using hot water or mild cleaning solutions. Please do not use chlorine or any chemicals containing chlorine.

Safety Cable Check: Each MacroAir fan comes with a safety cable. Depending on the fan model, the safety cable either wraps around the building structure and the fan frame or comes out of the top of the fan and wraps around the building structure. The safety cable is an important part of the safety system and acts as a last resort should an earthquake, collision, or similar catastrophic event occur. As such, it's vital for fan owners to ensure that the safety cable is intact and properly secured.

Reverse Operation: The beauty of MacroAir HVLS fans is that they are built to run in forward and reverse mode. However, changing the direction of your fan can put initial stress on the fan if it has not been properly checked. It is a good idea to make sure safety cables and all bolts and nuts are tight. Cleaning the fan before switching directions will prevent dust and other particles from falling off the fan airfoils when turning in the opposite direction.

Maintenance Plan: Things to look for include properly torqued fasteners, rust, cracked welds, unusual noise, hub migration or movement.

Years 1-10: One inspection on lift per year.

Year 11 and beyond: Annual inspections from a lift and seasonal inspections both before and after the busy season from the ground.

NOTE: If there are issues or concern discovered during an inspection, please contact the service and technical support department at MacroAir for help.

CONTACT US: For installation assistance, application questions, technical sales support & any other inquiries, please contact us at **(866) 668-3247**.

Troubleshooting

Please refer to the table below if you experience issues with the fan operation.

Symptoms	Possible Solution
The fan is not turning and the lights on the VFD are lit.	Flip disconnect switch to "OFF" for 30 seconds and then flip to "ON". Ensure that the VFD is properly connected to the motor.
The fan is not turning and the lights on the VFD are NOT lit.	Confirm that there is power coming from the building.
The fan is making a loud "clicking" noise.	Ensure that the anti-seize was properly applied to every blade strut.
The fan is operating noisily.	Confirm that there is nothing interfering with any moving parts.
The fan is wobbling.	Confirm that the fan is level and properly installed and tightened.

If your issue cannot be resolved using the table above, please contact MacroAir technical support at **(866) 668-3247**.

Warranty

MacroAir warrants the Products listed in the table below will be free from defects in materials and workmanship under normal use and maintenance for the applicable Warranty Period. Other than the Warranty set forth in this document, no other written or oral warranties apply, and no employee, agent, dealer, or other person is authorized to give any other warranties on behalf of MacroAir.

START DATE OF WARRANTY COVERAGE

Warranty Period for X Series and AVD fans with 50,000 operating hours covers the Motor, Electrical Controls, and Remote for 50,000 hours of run time. For all other fans, the Warranty Period begins fifteen (15) days following shipment of the Product, or on the date the Product is installed (not to exceed sixty (60) days Customer receives the Product), whichever date is later. Customer should retain necessary documentation to verify the date of receipt and installation of the Product. Customer will be required to produce this documentation in order to obtain Warranty services from MacroAir. The Warranty specified herein applies only to Products purchased on or after October 31, 2019.

PRODUCTS AND SYSTEMS COVERED BY THIS WARRANTY AND APPLICABLE WARRANTY PERIODS:

Fan Type	Mechanical: Blades, Hub & Frame	Standard Electrical ¹ : Motor, Electrical Controls, Remote	Labor
X Series	Lifetime	50,000 Operating Hours	1 Year
Y Series	Lifetime	7 Years	1 Year
Z Series	Lifetime	5 Years	1 Year
AirVolution-D 780	Lifetime	50,000 Operating Hours	1 Year
AirVolution-D 550	Lifetime	50,000 Operating Hours	1 Year
AirVolution-D3	Lifetime	50,000 Operating Hours	1 Year
AirVolution-D 370	Lifetime	50,000 Operating Hours	1 Year
Airlite Shop Fan	Lifetime	2 Years	N/A

WARRANTY COVERAGE:

Subject to the exclusions herein, the MacroAir Warranty covers any defects in workmanship or materials of the covered Products under normal operation and prescribed maintenance when those defects adversely affect the ability of the Product to operate properly.² The Warranty only covers Products which have been installed in compliance with MacroAir's written installation instructions by a MacroAir approved installation technician or licensed electrical contractor and operated and maintained by the Customer in conformity with MacroAir's written instructions, and when the Product is purchased directly from MacroAir or a MacroAir Authorized Dealer.

This Warranty is subject to all provisions, conditions, limitations, and exclusions explained in this Warranty document.

*Scan QR code or visit macroairfans.com/warranty for full warranty information.



¹ "Standard Electrical" means any common electrical component that is utilized across more than one fan line will assume the higher warranty period.

² "Operate properly" applies only to mechanical, electrical, and structural systems of the Product.



794 South Allen Street
San Bernardino, CA 92408
(866) 668-3247
Macroairfans.com